



# BOMBER COMMAND MUSEUM OF CANADA NEWSLETTER



MUSEUM OPERATED BY:  
THE NANTON LANCASTER SOCIETY

VOLUME 31 ISSUE 1

SPRING/SUMMER - 2017

*The Society's Main Fund Raising event this year is a "Hangar Hootenanny" as per this advertisement.*

*This will be an informal "Gala", starting at 5:00 pm with refreshments, followed by a real country style roast beef dinner. Tickets are \$75 each with \$50 of this eligible for tax receipt.*

*There will be both a live and silent auction with some fabulous items to bid on, which include airplane rides, artwork, WWII artifacts and a chance to be a passenger in the Lancaster when its engines run-up at 10:00 pm.*

*We hope you will all come and support this effort to help fund the new 34,000 square foot addition to the museum. This will enable us to exhibit the many items that are presently in storage.*

## Hangar Hootenanny



at the  
Bomber Command Museum  
of Canada

### A Building Expansion Fundraiser

## Saturday, May 13

## 5:00 p.m. to Midnight Tickets \$75



Doors Open at 4:30 p.m. Refreshments 5:00 – 6:00 p.m.  
Supper 6:00 p.m. - prepared by the Stavely Royal Purple & Elks

### Unique Live and Silent Auction Items

- ½ hour sightseeing trip for three from Mountain View Helicopters
- One hour ride in Citabria & ½ hour ride in Cessna 172
- Aviation Art & Memorabilia and many handcrafted items
- 10:30 p.m. Lancaster FM 159 Merlin Engines Run

1659 – 21<sup>st</sup> Avenue, Hwy 2 South, Nanton, AB, T0L 1R0 (403)646-2270  
Tickets available at: [www.bombercommandmuseum.ca](http://www.bombercommandmuseum.ca)

**2017 BOARD OF DIRECTORS**

Rob Pedersen .....	Derek Squire
Ben Schwartz .....	Dave Birrell
Brent Armstrong .....	Charles Logie
Dan Fox .....	Rick Featherstone
Bob Evans .....	Karl Kjarsgaard
Carl Orde.....	Charlie Cobb
Bob Long .....	

**Volunteer positions**

<i>Honourary President</i> .....	<i>Don Hudson</i>
<i>President</i> .....	<i>Rob Pedersen</i>
<i>Vice-President</i> .....	<i>Dan Fox</i>
<i>Secretary</i> .....	<i>Karl Kjarsgaard</i>
<i>Treasurer</i> .....	<i>Derek Squire</i>
<i>Curator - Editor</i> .....	<i>Bob Evans</i>
<i>Anson Restoration</i> .....	<i>Rob Pedersen</i>
<i>Library &amp; Displays</i> .....	<i>Dave Birrell</i>
<i>Webmaster</i> .....	<i>Brent Armstrong</i>

**Office Staff**

<i>Office Manager/Event Coordinator</i> .....	<i>Dana Zielke</i>
<i>Visitor Services Manager</i> .....	<i>Ashley Burrows</i>

**NEWSLETTER CONTENTS**

<i>Executive list - Staff - Membership Options</i> .....	2
<i>President's report - Contact info - Museum hours</i> .....	3
<i>BC Cadets arrive to do spring cleanup</i> .....	4
<i>100th Anniversary of WWI Battle of Vimy Ridge</i> .....	5
<i>Expansion Report - May Auction items</i> .....	6
<i>Lancaster Report</i> .....	7
<i>Art Takes Flight Event</i> .....	8
<i>Western Canada Regional Model contest and show</i> .....	9
<i>Bikes and Bomber Day</i> .....	10
<i>Field of Dreams Car Show &amp; Editor's Comments</i> .....	11
<i>Avro Anson report</i> .....	12
<i>ORB Project and April 22nd Kick Off</i> .....	13
<i>In Memoriam</i> .....	14
<i>Rita Green Remembered &amp; Souvenir Book</i> .....	15
<i>Mosquito Restoration Report</i> .....	16 & 17
<i>Halifax Report</i> .....	18 & 19
<i>Salute to Group "6" Commemoration</i> .....	20
<i>Lanc out for Spring c heck up</i> .....	21
<i>Progress on the Cessna Crane Simulator</i> .....	22
<i>Merlin Engine Run Schedule &amp; Medal display</i> .....	23
<i>Supporters advertisements</i> .....	24

***BECOME A MEMBER OF THE  
NANTON LANCASTER SOCIETY******ANNUAL MEMBERSHIP - \$40.00******MUSEUM SUPPORTER MEMBER***

For a **\$250.00 donation or more** you become a **SUPPORTING** member and receive:

- A **certificate** stating you are a Square Footer member; with a **five year membership** c/w a bi-annual newsletters;
- **Your name placed on a virtual plaque** in the museum;
- An **official tax receipt** for income tax purposes.

***LIFETIME MEMBERSHIP***

For a donation of **\$1000.00 or more**, you become a **LIFETIME MEMBER** and receive:

- A **Lifetime member certificate**; your name on a **Virtual plaque** in the museum;
- an **official tax receipt** for income tax purposes; **bi-annual newsletter**.

***WING COMMANDER'S CLUB***

For a donation of \$5000 or more **you** become a member of the **WING COMMANDER'S CLUB** and receive:

- **all the rights of a Lifetime member.**
- PLUS your name on a special permanent plaque on the Wing Commanders board.**

The Nanton Lancaster Society is a non-profit, volunteer society, registered with Revenue Canada as a charitable organization and is pleased to issue tax receipts for donations of funding or materials.

The Society is working toward restoration of Nanton's Lancaster Bomber and development of the Air Museum with this historic aircraft as the centerpiece. The museum honours all those associated with Bomber Command and commemorates the activities of the British Commonwealth Air Training Plan.



## PRESIDENT'S REPORT

*By Rob Pedersen*

Spring has sprung and the staff and volunteers at the museum are out and about just like busy little bees. This season our schedule is once again full and the museum will indeed be a hive of busy activity. Major themes this year at the museum will include a salute to our volunteers during volunteer week, fundraising for our Museum expansion at our HANGAR HOOTENANNY, celebrating the 150<sup>th</sup> birthday of Canada and recognizing the Canadian Contribution in WWII by Bomber Command with the 6 (RCAF) bomber group commemoration. Plus we will be hosting the 2017 Canadian Aeronautical Preservation Association Convention.

Our museum lives and runs on its volunteers. Our first event out of the gate on April 22 will salute our great gang of volunteers. Whether it be greeting visitors at the front desk or swinging a hammer in the shops, our volunteers are our driving force. They are the back bone of this museum. I can't say enough good things about the people who support the museum.

I must include the board of directors in that group. While many organizations have paid directors, our board is 100% volunteer. Not only does the board direct and guide the museum but each member will often be found twisting wrenches on a Tuesday night or greeting visitors at the front door.

For updates and our current schedule call us at 403-646-2270 or check our Website at: [WWW.bombercommandmuseum.ca](http://WWW.bombercommandmuseum.ca).

We look forward to seeing you all at the museum this summer.

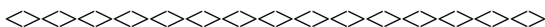

## CONTACT INFORMATION

3

### Office Manager:

office@bombercommandmuseum.ca

### Visitor Services:

visitorservices@bombercommandmuseum.ca

### Curator:

curator@bombercommandmuseum.ca

**Telephone: (403) 646-2270**

**Fax No. (403) 646-2214**

### Website:

www.bombercommandmuseum.ca

### Mailing Address:

**Bomber Command Museum of Canada**

**P.O. Box 1051**

**Nanton, Alberta**

**Canada T0L 1R0**

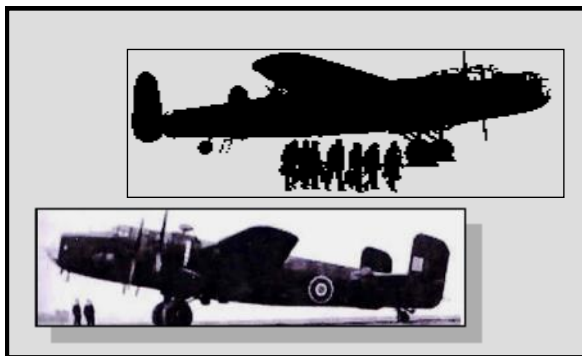

## MUSEUM HOURS

**April 16 to June 30**

**(open daily 10:00 a.m. - 4:00 p.m.)**

**July 1 to August 31**

**(open daily 9:00 a.m. - 5:00 p.m.)**

**September 1 to October 15**

**(open daily 10:00 a.m. - 4:00 p.m.)**

**October 16 to April 15**

**(open Fri, Sat, Sun 10:00 a.m. - 4:00 p.m.)**

\*\*\*\*\*

**To book group or special visits**

**Call 1-(403)-646-2270**





*Air Cadets from 279, 552, and 904 Squadrons, relax for a photo after cleaning the museum.*

### **BC CADETS DO A CLEAN-UP**

The 279 Elk Valley, Cadet Sqdn. from Elkford/Sparwood, BC, under the direction of CO Capt Murray Clow and the 552 Key City Sqdn. from, Cranbrook BC with CO Capt Lori-Lee Bott and 904 Kootenay, Creston Sqdn, and CO Capt Rob Bott arrived March 31st on their annual spring visit to clean up our museum!

These cadet Squadrons have been doing this for many years and they in reality start off the museum`s spring/summer busy season.

Our GRATEFUL THANKS go out to these young people for their efforts on our behalf !!

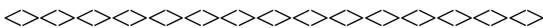

*Cadets clean the dust from the large Halifax model that hangs over the gift shop*



*One of the cadets tidying up the mannequins.*



## 100TH ANNIVERSARY CEREMONY OF THE BATTLE OF VIMY RIDGE

*By: Marylou Slumskie*

Sunday, April 9 was the 100th anniversary of the Battle for Vimy. The Royal Canadian Legion, Nanton Branch 80 organized a service to commemorate this epic battle & the Canadian bravery and sacrifice.

There was a short service at the Nanton Cenotaph on that day - the day was much like the weather in France 100 years ago with cold winds & snow. The service was led by Nanton, Branch 80 Chaplain - Susan Wilkinson-Matticks who spoke of the Battle and its connection to Nanton.

Nanton, Alberta is directly connected to the First World War. Our cenotaph bears the names of 25 men who made the ultimate sacrifice. The Vimy Ridge Planning Committee posed the question whether any of those names from the First World War might have actually been involved at Vimy Ridge; they asked WWI historian and author Susan Raby-Dunne, who does research at the Bomber Command Museum, if any

of those 25 names could be linked to the four-day battle at Vimy. 5

Susan's research revealed that 7 of those 25 very likely did participate as a part of the Canadian contingent during the battle for Vimy Ridge. Susan's research effort was very much appreciated & quite remarkable that the little town of Nanton contributed so very much.

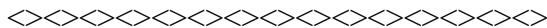

*Dan Fox lays a wreath at the Cenotaph on behalf of the Bomber Command Museum while the Legion Honour Guard stands at attention. Photo by Steve Sucha Nanton News*



*District Commander, Wayne Shaw & Branch # 80 President, Dick Fenton about to cut the special cake.*

**The seven Nantonites who fought in the WWI battle of Vimy Ridge were:**

-----  
**William E Buchanan** ,13<sup>th</sup> Battalion

**John Ingram** - 31<sup>st</sup> Battalion

**David Kennedy** - 10<sup>th</sup> Battalion

**Arthur D. Melvin** - 10<sup>th</sup> Battalion

**Albert Parker** - 10<sup>th</sup> Battalion

**Owen Pestell** - 10<sup>th</sup> Battalion

**Oscar C. Williams** - 31<sup>st</sup> Battalion

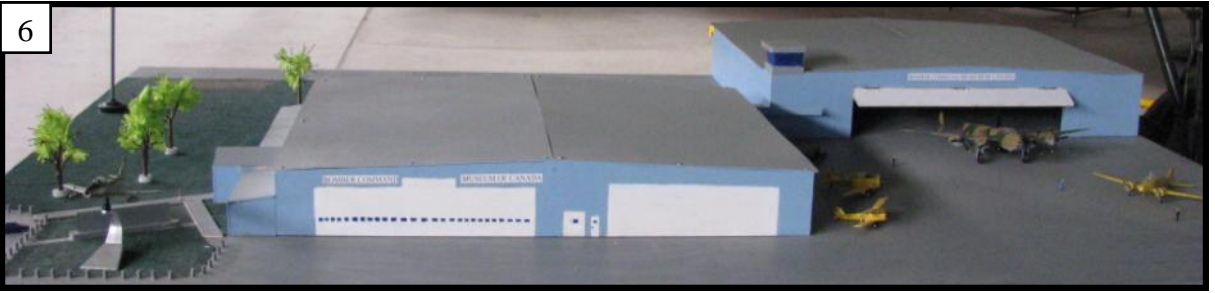

— Model showing new building cornering the existing museum and the new tarmac area. —

## MUSEUM EXPANSION REPORT

*By Dan Fox, Expansion Committee Chair*

May 13, 2017 will be our next major fund - raising event - a “Hangar Hootenanny”. This will be a more informal “Gala”, starting at 5:00 pm with refreshments, followed by a delicious roast beef meal at 6:00 pm.

Our MC for the evening, will be renowned speaker and former museum tour guide, Chris Koch. Chris has done motivational presentations all over the world and has a wicked sense of humour.

You may view, at any time, the great silent and live auction items on hand, including airplane rides, artwork, WWII artifacts and a chance to be a passenger during the Lancaster engine run-up at 10:00 pm.

Bernie Lalonde will be our auctioneer for the evening, starting at about 8:00 pm. (Donated auction items would be greatly appreciated and accepted until May 10th).

Tickets are available for \$75 each (\$50 of which is eligible for a tax receipt), at the museum or online at:

[www.bombercommandmuseum.ca](http://www.bombercommandmuseum.ca)

We welcome your support so we can get started on our much needed expansion.



## DONATIONS FOR THE AUCTIONS

*At The*

### “HANGAR HOOTENNANY”

The photo above shows only one of the many donations that have been received. This consists of 60 airplane model kits, some of which are no longer available from model vendors.

Both the live auction and silent auction will have some very nice items. Also our auctioneer Bernie Lalonde can be very entertaining as he convinces people to bid!



## LANCASTER REPORT

*By Bob Evans*

While other work was accomplished on the Lancaster over winter, the main happening was the reinstallation of Merlin #1 on the bomber. It had been off the aircraft since last fall due to an oil leak from the supercharger. The back housing had been sent to Vintage V-12s in California for repair. It arrived back in March and was fitted back in place. The photos on this page show a sequence of it being reinstalled on FM-159.

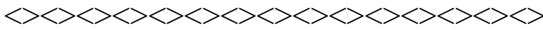

7

*Lining the engine up with the fire wall.*



*While Ben holds it in place with his hoist, Greg Morrison, and Shane Chipchase secure the attach bolts on one side while Brian Taylor (hidden behind the engine) installs them on the other side with Derek Squire in the lower right assisting.*



*Merlin #1 reassembled ready to reinstall.*



*Ben Schwartz operates his picker-truck to lift the Merlin for reinstallation on the Lanc.*



*Carl Orde and Greg Morrison move the propeller into position for installation.*

### ART TAKES FLIGHT

Mark June 3<sup>rd</sup> on your calendar for *“Art Takes Flight”* at the Museum . This Building Expansion Fundraiser features 25 professional artists from Calgary, Okotoks, High River, Carsland, Cayley, Fort Mcleod and Nanton. On exhibit around the Lancaster will be paintings, glass art, jewellery, fibre art, photography, sketches and even, cigar box guitars.

Themes expressed by the artists will be everything from nose art, contemporary to western and many more in between. This eclectic, original art and one-of-a-kind collector works are seldom gathered in one place and this the first such exhibit in the Museum.

The artists will contribute 20% of their sales to assist the Bomber Command Museum’s Building Expansion Fund. Come for the art and stay for the planes on June 3rd from 9 to 5.

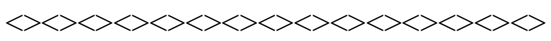

# Art Takes Flight

## Exhibition & Sale

**Saturday, June 3, 2017**

**9:00 a.m. to 5:00 p.m.**

- |   |                           |                                 |
|---|---------------------------|---------------------------------|
| Denise Archambault, Calgary             | Bev Fox, Nanton           | Tieggan Rouleau, Fort Macleod   |
| Cathy Bennington, High River            | Sandy Heavens, High River | Virgini Senden, Okotoks         |
| Joyce Brown, High River                 | Kim Holowatiuk, Carseland | Marg Smith, Okotoks             |
| Crocus Country Fibre Arts Guild, Cayley | Bruce Koch, Nanton        | John Smith-Jones, Calgary       |
| Jan Daley, Fort Macleod                 | Adam Lagace, Calgary      | Arlene Westen-Evans, High River |
| Gerry Dilschneider, Nanton              | Maggie McNeil, Calgary    | P. Susanah Windrum, Calgary     |
| Janet Feist-Sippola, Nanton             | JD Moor, Nanton           | Claudia Zakrisson, Calgary      |
| Milt Fischbein, Calgary                 | Ralph L. Nelson, Nanton   | Dana Zielke, High River         |
|   | Shirley Paradis, Okotoks  |                                 |

A Building Expansion Fundraiser for  
**Bomber Command Museum of Canada**  
 1659 – 21 Ave, Hwy 2 South, Nanton, AB  
 403-646-2270



*Pictured here are examples of the kind of art that will likely be available.*

## WESTERN CANADIAN REGIONAL MODEL CONTEST -JUNE 10th

The museum, in association with the Rocky Mountain Model Club, will again be hosting this major model display and competition. As in previous years the entire hangar will be filled with hundreds of beautifully crafted models of all types and there will be various distributors selling model kits and related materials. We'll be running the Lancaster Merlin's that day as well.

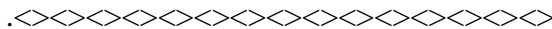

*Photo showing some of the tables with contestants models displayed at a previous WCR Model contest held in the museum.*



*The accumulation of vendors in the north hangar who attended a previous event. They will be attending the 2017 event.*

## SPITFIRE PROJECT REPORT

*By Rick Featherstone*

This past winter has seen some changes and some good strides forward for the Spitfire.

We have acquired frame 19 which is near the tail of the aircraft, we have also acquired a pair of axles that are new-made so when we are able to put the aircraft on her wheels, we will be able to roll her out to the tarmac for her to get some sunshine. Also acquired is a replica armor plate that is located directly behind the pilot. We have been working on the rusty tail wheel leg and the swivel at the bottom to try to get it free. It is still stubborn and doesn't want to move. This is being done very carefully so as not to damage anything,

A few pieces have been made for the bubble canopy. We are still waiting on the front steel framing of it in order to start re-assembly.

There are quite a few items on the horizon but we need to raise more funds to acquire the starting point of our re-build which is Frame 5 and is also the firewall.

We are anticipating a great coming season and have some new items for sale to promote the build of our Spitfire. We hope to see you out at one of our great events.

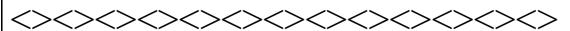

## ANNUAL BIKES AND BOMBER DAY JULY 9th, 2016

Last year's Bikes and Bomber Days saw a the arrival of some 200 different makes and models of bikes. Attending also were visitors who came to look over the many different makes and models. There were bikers attending with side cars who gave rides to interested viewers. Some had interesting quality artwork on their bikes.

Of course these same visitors were on hand for the running of the Lancaster's four Merlin engines. Also started up was the Bristol Hercules radial engine, this is always an exciting part of any event. Its noise and initial smoke screen has the visitors holding their ears and moving up-wind.



*Bikes and more bikes!*



*Visitors line up to go through the Lancaster between engine runs.*



## Bikes & Bombers



**Saturday, July 22, 2017  
10:00 a.m. to 3:00 p.m.**

Lancaster Bomber Merlin V-12 Four Engine Runs 11 a.m. & 2 p.m.  
Bristol Hercules Engine Runs  
Exclusive Motorcycle Parking Area on North Ball Diamonds  
Lunch Concession in North Hangar  
Ride in and get your "Participation Patch"!

**A Special Day for Motorcycle Enthusiasts at the  
Bomber Command Museum of Canada  
Hwy 2 South at 17<sup>th</sup> Street, Nanton, AB**



## FIELD OF DREAMS

### SHOW AND SHINE CAR SHOW

While this event isn't a museum event it will take place this year on, **July 22nd, the same day as the BIKES & BOMBERS event and adjacent to the museum.**

This Show & Shine event was held in Nanton a couple of years ago. The cars on show ranged from vintage, sports, and hot-rods to fancy European makes, and more!

So anyone attending the Museum's event will have an extra venue to visit and vice-versa!

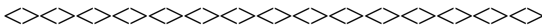

*The above photos are just a sample of the cars that will be exhibited at the Field Of Dreams Show and Shine on July 22th 2017.*

## EDITOR'S COMMENTS

11

I'm still at it! The newsletter that is. I believe we have here-in covered all the over-winter news or at least given you a micro picture of what happened during that time.

Other contributors have pretty well covered the many upgrades and further work that has taken place on long-term projects like the Avro Anson, and the Calgary Mosquito rebuilds.

The Cessna Crane simulator project has seen a surge forward after being stagnant for a couple of years. Most of the credit goes to Kevin Charlton, who has done most of the work. This thing called "old age" has limited what I can do !

Kevin, who is fairly new to Nanton, builds and repairs guitars for a living. His work is meticulous and this old retired farmer/house builder/curator has had to toe the mark.

The application of the fabric covering was new to both of us. Under AME Greg Morrison's careful tutelage we applied the fabric and have it stretched over the framework. We are now down to the final stages of applying the poly dope. One coat brushed in and several spray coats left to go!

After the delivery of two exhaust fans to ventilate our improvised paint booth we will be on with the job again.

Hope to see you at our summer events. Looking forward to reporting our summer events in this fall's newsletter.

**BEST REGARDS TO ALL** *Bob Evans*

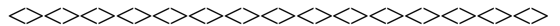

They say slow and steady wins the race ... if that is a true statement then Annie is well on the way to being a winner. Every week there is a new piece on Annie and the progress is noticeable. Control cables are now mostly in place, Stringers now adorn the aft fuselage giving Annie her wonderful shape. The electrical project has picked up the pace. After much deliberation as to what materials are actually needed, those materials are on order, and soon (soon in the time frame of Ansons) the miles and miles of wiring will begin to appear along her starboard wire chase.

A new project that has been picked up is the restoration and installation of her Hydraulic system. Several trips out to the Anson crop yielded the required components to complete her system with the exception of her hydraulic pump (The heart of the system). Sadly much searching of our spares did not yield the elusive and much desired pump. However on a good note the old adage of you'll find it when you're not looking for it held true. Yours truly was rummaging around looking for trailing edge components when I just happened to look over at the parts shelf. A shaft of light shone down on this lone component sitting there. Lo and behold it was the Hydraulic pump! Strange thing is that I know that I had searched the shelf several times before it wasn't there ...

Trailing edge (Ken & Malcolm) continue to disassemble the trailing edge as much as they dare. New drawings are being made from old patterns and luckily most of the

ribs are being repaired instead of having to be recreated. A great story for the restoration of old Annie (7481).

Fuselage: (Carl and Terry) the aft stringers are now almost 100% installed and as soon as the last of the control cables are run the belly stringers will follow.

Tail plane. All major structures are now completed and as such, efforts are now turned to the tail cone mounting structure. This is the last piece to be placed before the skins are applied and the tail plane readied for its colour coats!

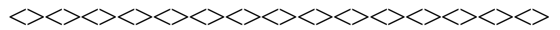

*In the trailing wing edge in the background.  
In front one of its ribs being rebuilt.*



*The aileron attach brackets are now being installed on the horizontal stabilizer.*

This first event of the 2017 summer season is fast approaching, as this newsletter is being assembled.

The themes are: “**Commemorating the First Lancaster Ops,**” and “**A Salute to the Volunteers.**”

The Lancaster will be out and it’s Merlins will be run-up twice, (at 11:00 am and again at 2:00pm). Following these engine runs, that “loud” smoke producing thing called a **Bristol Hercules engine** will also run. As the smoke clears, those on hand viewing this will be seen holding hands over their ears and moving upwind from the smoke cloud!

There will be a ‘Spitfire’ table with items for sale and the museum will be open with its gift shop for those looking for souvenirs.

All in all it appears that it will be an event that sets the stage for the several up coming summer events.

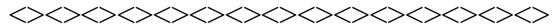

*The running of the Lancaster’s four Merlins is a spectacular sight! Come see for yourself on April 22nd or one our other events.*



*The fuselage turtle-deck frame stringers all in place. Some previously built fuselage formers had to be redesigned and replaced.*



*Some of the electrical panels restored*

### THE ORB PROJECT

Our museum has received copies of the Operational Record Books and other documents related to the Canadian Bomber Squadrons operations during WW II. However, they only exist in a somewhat “mixed-up” state and are difficult to make use of as we do research.

Fortunately, two of our museum volunteers have taken on the project of going through this vast amount of material and sorting the documents into a system whereby the information is much more readily accessed.

The museum regularly responds to enquiries regarding airmen who served on these squadrons.

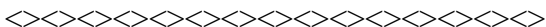

## IN MEMORIAM

**Thomas “Tom” Murray Quibell**, Co-mox, BC. Passed away December, 13 2016. A long time member of the Bomber Command museum.

**Norm Etheridge**, Milton, Ontario, departed this earth January, 27, 2017. He was a museum member, supporter and friend whose advice guided the local members in their creation of the museum from one tired old Lancaster to what it is today!

**Mrs M. Rita Green**, Nanton, AB went to her reward February, 28, 2017. Rita, was involved from the very beginning in the creation of the Bomber Command Museum of Canada. A long time member, supporter and volunteer!

**Margaret Kathleen Fisher**, Nanton, AB, passed away February, 16th 2017. Margaret was a museum member and supporter.

**John “Jack” Abbott**, North Battleford, Sask. Passed away March 24th, 2017, one week after celebrating his 97th birthday. Member and supporter.

**Betty Stoba**, Nanton, AB Passed away on October 27, 2016. Betty was long-time member and supporter of the Museum.

**William Edwin Rooke**, Brooks, AB, Former RCAF tail gunner and long time BCMC member passed away April 1st 2016



**NORMAN ETHERIDGE**

*Our good friend, Norm Etheridge - departed this earth on January 27, 2017. Our association with Norm began back in the fall of 1987, when four members of our newly formed Nanton Lancaster Society travelled to the Canadian Warplane Heritage Museum in Hamilton, Ontario to find out just what was involved in restoring a Lancaster. CWH's Lancaster, FM-213, was being restored to fly*

*We were welcomed by the project's chief engineer, Norm Etheridge, and the others of his restoration crew. Over the years Norm visited us on several occasions, and was guest speaker at one of our events.*

*Norm's advice was always available over the years, without which our restoration of Lancaster FM-159 would have been severely hampered. Norm Etheridge was a friend indeed! May he rest in Peace!*

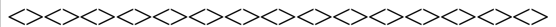



**MARGARET 'RITA' GREEN**

*Our friend and long time supporter of the Museum, **Rita Green**, passed away February 28, 2017.*

*Since the Nanton Lancaster Society was formed in 1986, Rita along with her husband John have put in countless hours, promoting the preservation of the Lancaster Bomber and the history it represents.*

*Our museum was not the only entity that Rita was involved with. Along with her husband she was very involved in the International Flying Farmers organization. They flew together all over North America to attend conventions and fly-ins.*

*Rita was very active in the Nanton Community, volunteering countless hours where ever there was a need.*

***Rita Green will be dearly missed by all who knew her.***

**MAY GOD BLESS**

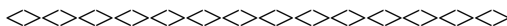

## THE BOMBER COMMAND MUSEUM OF CANADA



*Dave Bivell*

### **BOMBER COMMAND MUSEUM OF CANADA SOUVENIR BOOK REVISED**

If you're unable to travel to the museum or would like a reminder of your visit:

**Our new "souvenir" book is available as a free download.**

**[http://www.bombercommandmuseum.ca/book\\_bombercommandmuseum.html](http://www.bombercommandmuseum.ca/book_bombercommandmuseum.html)**



## THE CALGARY MOSQUITO SOCIETY REPORT

*by: Richard de Boer, Prez*

Your friendly tenants in the north hangar spent another productive winter battling tenacious termites and crystallized glue in our ongoing fuselage restoration efforts. With an abundance of volunteers we are able to tackle a lot of areas at the same time. The cockpit floor has been restored with a great deal of work undertaken in the area below, fixing the bulkhead and former problems. As much as possible we reuse the original wood, replacing it only as a last option.

Recently we removed the centerline strips joining the two fuselage halves from the windscreen to the nose. Much of the old glue has crystallized and no longer provides any adhesion. As well, the outer plywood skins have started to separate along the joint



*Inside the Mossie fuselage to do repairs. This has to be called "getting right into your work.!"*

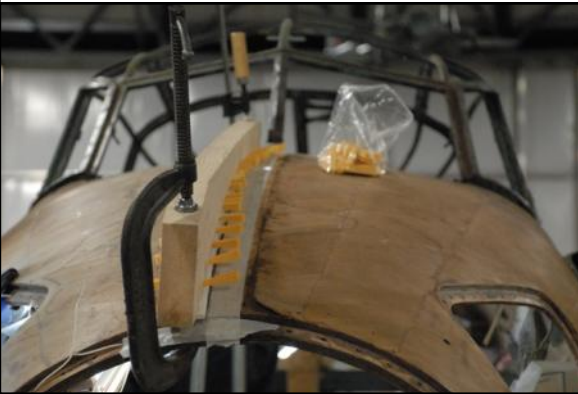

as well. The crew, led by Jack McWilliam, has come up with some very creative solutions to issues that were never anticipated by de Havilland during the war. Had an airframe suffered any of these problems it would have been scrapped and replaced.

The crew has also spent a lot of time on the two frame areas forward of the cockpit. Water had damaged a lot of the wood and glue here as well. Additionally a lot of the crew has spent countless hours inside the fuselage with everything from dental picks to belt sanders to remove the many layers of paint. Goggles, masks and body suits are a necessity for this very grubby and tedious work.

We are also devoting significant time to sorting, identifying, labelling and



*Another "inside job." A CMS volunteer works at a repair inside the fuselage.*



*The CMS Hurricane's fuselage seen here in an advanced stage of being restored.*

cataloguing the many crates of parts we acquired with the airplane and those we have purchased over the past few years. If you don't know what it is, or where it goes, or if you need one, it's no good to anyone.

Our thanks to Rick Featherstone who continues to build up the cockpit instrument panels for us. This is a challenging task even for an old hand like Rick as each model of the Mosquito seemed to have its unique instrument panels and layouts. An additional complication is that ours is a British built Mosquito with post war civilian North American modifications to it. Our thanks to Rick as well for building up the Hurricane instrument panels.

We still anticipate having the Hurricane complete by the end of this year. We have acquired additional guns for it (now up to 10, with 2 more required) and we seem to have broken the parts embargo against us by vendors in England which will allow us to complete all the systems on the airplane. This has been a major problem for this project.



*The Hurricane's fuselage exhibited with the spare Merlin below.*

## Halifax 57 Rescue (Canada)

[www.57rescuecanada.com](http://www.57rescuecanada.com)



**WE STILL NEED YOUR HELP!**

DONATE NOW TO ONE OF THESE SITES

<https://fundrazr.com/417498>

<http://www.57rescuecanada.com>

### Help us Save a Halifax for the Bomber Command Museum of Canada!

Greetings to all of our membership of Halifax 57 Rescue and keen supporters of the Bomber Command Museum of Canada for saving RCAF Halifax HR871 off the coast of Sweden! Our Swedish team of divers and historians of Swedish Coast and Sea Center (SCSC) are rallying their resources and dive teams to get ready for the end of April to begin this summer's dives and excavation of the Halifax from the sand off of Falsterbo, Sweden.

I will be traveling to Sweden at the end of next month to be there to help kick-off the recovery efforts for 2017 as we gear up to uncover the airframe and bring it back to land at the Port of Trelleborg, Sweden.

Our friends at the Port have provided us with a great asset to the recovery as we are receiving warehousing and tools, including cranes and vehicles, to receive the Halifax airframe as it comes out of the Baltic Sea after 73 years. Then the conservation and preservation of this Halifax treasure can really begin.

Jan Christensen, our lead diver, is working hard to gather all resources and set up the dive teams to be ready to literally "dig-in" to move much sand when the recovery operations start. To review this is the basic

description in this diagram of the digging out of the 10 - 15 tons of Halifax we have plotted at the site.

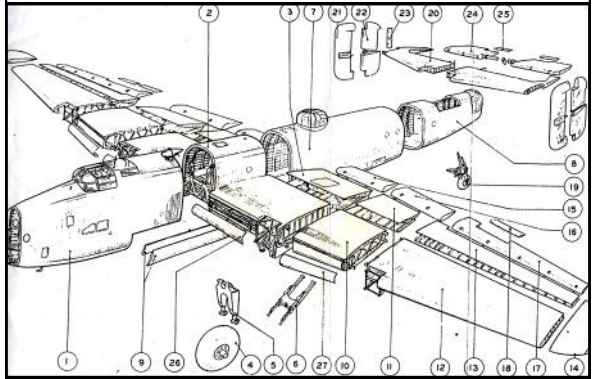

On the home front, as promised "SPRUNG Instant Structures" took our 1942 Halifax wing blueprints, machined a die, and extruded 2 full sets of Halifax rear wing spars - (10 sections) Five sections of these are for the Halifax center-section we are presently building up at the "KNOX Tech." rebuild shop in Ottawa. So while we are working on lifting Halifax HR871 in Sweden, Scott and his guys are already building us the NEW Halifax foundation! See the photo (on page 19) of the new rear spars arriving from the factory in the USA to Alberta. They are now in Ottawa.

On to fundraising. As promised I have, written up and sent a detailed 15 page proposal applying for a grant from the federal government of Canada. This proposal has been sent to the Ministers of Canadian Heritage and Veterans Affairs asking their Ministries to support our Halifax Sweden Project.

Also have I sent this proposal to other political persons requesting help to strengthen our grant proposal. I have not yet heard



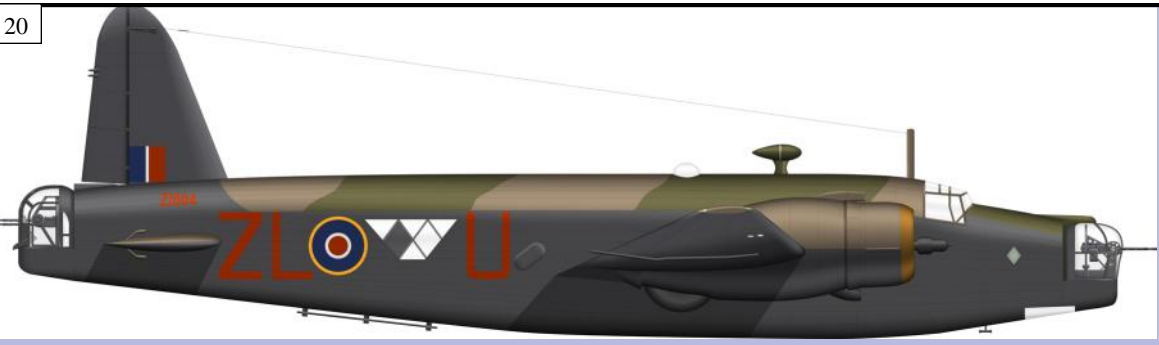

*“On 3 January 1943, 427 Squadron RCAF Wellington Z1604 was the first aircraft to takeoff as part of a 6 Group operation.”*

### **August 19, 2017 A SALUTE TO**

#### **“6 GROUP COMMEMORATION” -**

Although hundreds of Canadians were serving with Bomber Command in Royal Air Force squadrons at the outbreak of war, the Canadian involvement was one that grew as the war progressed. 6 Group RCAF Bomber Group was formed during October 1942, becoming a force of fourteen squadrons. The Canadian Group flew a total of 40,822 sorties. 271,981 hours were flown, and 814 aircraft were lost. 10,250 Canadians were killed serving with Bomber Command. The formation of this “All Canadian” RCAF bomber group during WW II was a significant milestone in Canada’s history.

A museum event on August 19<sup>th</sup> will commemorate the 75<sup>th</sup> Anniversary of the formation of 6 Group RCAF. Some details are available on our website now and more will be added as the date approaches.

However, we do know that:

- Our guest speaker will be Royal Military College professor David Bashow, author of “No Prouder Place - Canadi-

ans and the Bomber Command Experience.”

- The “Brass Quintet” RCAF Band from 4 Wing Cold Lake will be performing.
- We have requested a CF-18 Hornet Flypast and a static display by 408 Helicopter Squadron.
- New museum displays honouring the history of 6 Group will be unveiled.
- We will be running and taxiing our Lancaster Bomber, our Fleet Fawn will be run-up, and we’ll be starting up the Bristol Hercules Radial Engine.

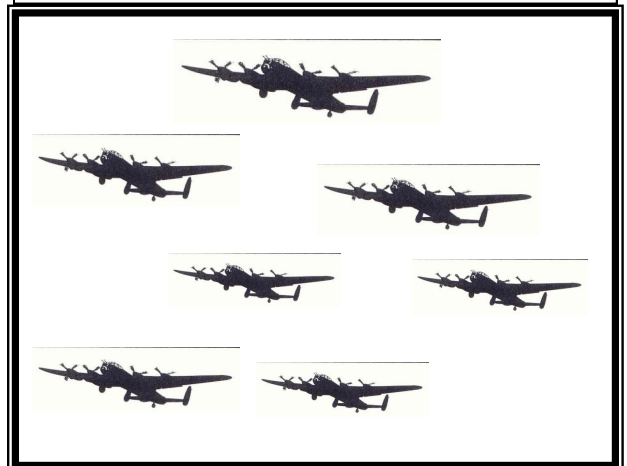

## LANCASTER FM-159 ROLLED OUT FOR SPRING CHECK UP

FM159 was rolled out in early April in preparation for this summer's running of the Merlins. This was the first running of No.1 engine, since it was taken off last fall.

The rear supercharger housing was sent to California for repair and was reinstalled this spring. The engine started right off after some tweaking.

We understand the Lanc crew will be doing some more adjusting prior to the first official running of the four Merlins on April 22nd. The photo to the right shows it running!

Again our Lanc crew have done a great job! We extend our congratulations for their continuing preservation efforts in upgrading and maintaining the museum's centrepiece. The crew does not need to take a back seat to anyone in the restoration business!

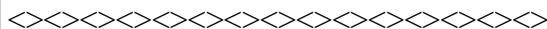

*Fueling up for the coming season's engine runs - Greg Morrison standing by the truck, Todd Lemieux on the supply tank, Charles Logie up on the wing.*



*No.1 Merlin (port-outer) back on the Lanc after being off for repairs over winter. It ran at the first attempt! However the Lanc crew have been doing a few more adjustments since that run-up.*



*Lancaster FM-159 outside for a test run of the # 1 Merlin after having had some upgrading over the past winter.*

**ENGINE RUN - UP  
SCHEDULE  
TURN TO PAGE 23  
FOR THE LANCASTER ENGINE  
RUN DATES**

**THE NEW SIMULATOR'S MARKINGS.**

The flight simulator currently in use at the museum is placed within a cockpit section of an Avro Anson twin-engine training aircraft. It is very popular with our visitors and for this reason a second will soon be available, this one placed within a cockpit section of a Cessna Crane twin-engine training aircraft. Both Ansons and Cranes were widely used at Service Flying Training Schools of the BCATP.

**The new simulator will carry the markings of a Cessna Crane that served with 3 SFTS at Calgary. Crane 8127, that was involved in a mid-air collision with a Harvard over Calgary during WW II.**

After completing a bombing exercise, Crane 8127 was preparing to land at 3 SFTS. The 37 SFTS Harvard had been practicing formation flying and was on a southerly course over the city prior to turning to land at 37 SFTS. Likely enjoying some free flying, the pilot carried out a loop and was about to complete a second. Suddenly, the Harvard and Crane collided. A wing was torn off of the Crane which plunged to the ground onto 19th Avenue, just south of downtown.

The Harvard's pilot, LAC J. Major, tried desperately to control his damaged aircraft. It circled the Stampede grounds, eventually crashing into the infield and exploding, killing LAC Major.

LAC J. L. Ayton had been sitting near the door of the Crane. He was able to jump, deployed his parachute, and landed near the wreck. The pilot, Sgt. J.D. Hardiman, and student pilot LAC M.V. Eckert were killed.

Seriously burned when the Crane exploded were milkman John Tawes and five year old Terry McDonough, who often accompanied John on his rounds through his neighborhood. The milkman's horse had to be put down. Terry recovered and later became a pilot in the RCAF.

When the simulator is placed on display, we will commemorate this tragic event.

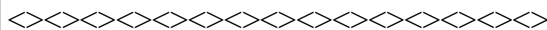

*The top photo shows the fuselage with the Poly-fabric glued in place. The bottom one shows the fabric after it has been shrunk and tightened with a seamstress's iron. If you look close you see the difference. Kevin Charlton stands beside his handiwork. The Crane is now ready for the final "doping."*



# GCS AUTOMOTIVE REPAIRS

Grant Gataiant

Journeyman Technician  
Powerstroke Diesel Specialist  
Automotive System Diagnostics  
General Automotive Repairs

AMVIC  
Licensee

P.O. Box 1392  
Nanton, AB. T0L 1R0  
2506 - 19 Ave. (Elevator Rd)

Phone: 403-646-3222  
Fax: 403-646-3224

Buy

Sell



# Nostalgia

Antiques & Collectibles

Pat Blake

2102 Main Street  
P.O. Box 107  
Nanton, Alberta  
T0L 1R0

(403) 646-5851

## THE CHANGING SEASONS BED & BREAKFAST

\*\*\*\*\*



1801 - 26 Ave.  
PO Box 1317  
Nanton, Alberta  
T0L 1R0  
21st Century Luxury

Phone: 1-(403) 646-1187 Toll Free: 1-866-464-6018

◇◇ Website: [www.thechangingseasonsbandb.com](http://www.thechangingseasonsbandb.com) ◇◇

# lexi.net



(403) 262-6610

## MAJA CONSTRUCTION INC.



**Jakob Hensel**  
Owner / Operator

403-646-2908  
403-336-3508  
PO Box 1711  
Nanton, AB. T0L 1R0

Jakob@MAJAConstruction.com  
[www.MAJAConstruction.com](http://www.MAJAConstruction.com)

## Western Financial Group

Insurance - Investments - Agency Banking

2207 - 20th Avenue, Nanton, AB

Phone: (403) 646-2900

Fax: (403) 646-2240

## BEAUCHAMP ALBERTA MARINE & AUTO

PHONE: 403-646-2215

FAX: 403-646-2759



WEBSITE: [WWW.BEAUCHAMPGM.COM](http://WWW.BEAUCHAMPGM.COM)

# Quality AI Interiors

AMO 67-00

**Servicing Rotary  
and Fixed Wing Aircraft  
for 10 Years**

**NOEL SMITH**  
General Manager

Tel. 204.252.2599  
Fax. 204.252.3103  
Email. [smithuph@mts.net](mailto:smithuph@mts.net)  
Box 1561  
Portage la Prairie, Manitoba  
R1N 3P1

[www.qualityaircraftinteriors.com](http://www.qualityaircraftinteriors.com)